

PRODUCT DRAWING

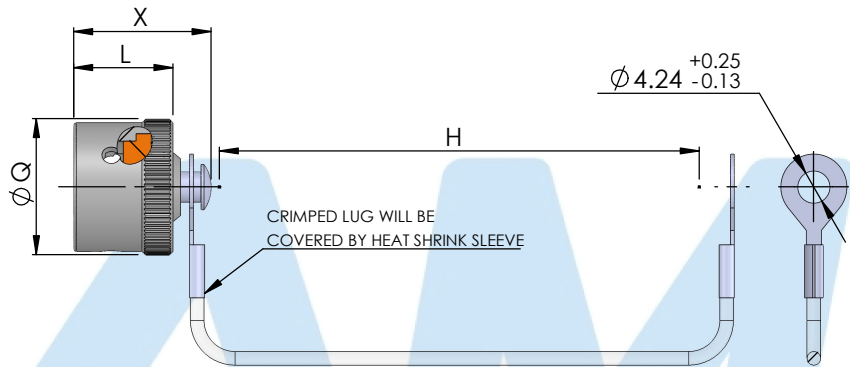

STYLE " R "

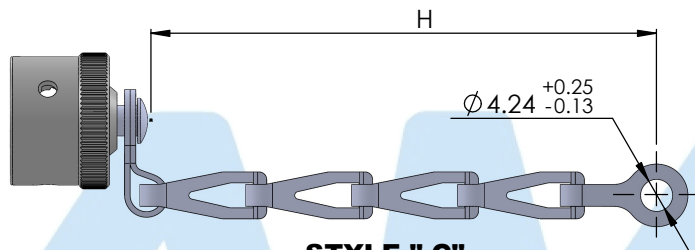

STYLE " C "

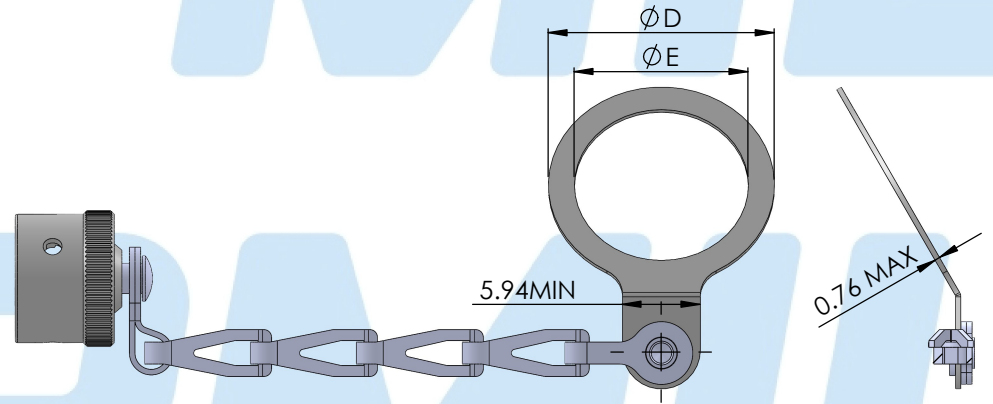

STYLE " N "

FOR ORDERING REFER AMPMIL
"HOW TO ORDER DOCUMENT"

SPECIFICATION			
NO.	PART NAME	MATERIAL	REMARKS
01	SHELL	ALUMINIUM	AS PER ORDER
02	FASTENERS	STAINLESS STEEL	PASSIVATED
03	RING	STAINLESS STEEL	PASSIVATED
04	CHAIN	STAINLESS STEEL	PASSIVATED
05	GASKET	SILICON ELASTOMER	NATURAL
06	INSULATED ROPE	7STRAND STAINLESS STEEL	PASSIVATED
07	LUG	STAINLESS STEEL	PASSIVATED

SHELL SIZE	ØQ	X	L	ØD	ØE	H
	MAX	MAX	MAX	MAX	MIN	+12.7 -6.35
8	18.64	21.44	14.27	22.62	14.68	76.2
10	21.82	21.44	14.27	25.4	17.86	76.2
12	25.4	21.44	14.27	30.18	22.63	88.9
14	28.58	21.44	14.27	36.53	25.81	88.9
16	31.75	21.44	14.27	39.67	28.98	88.9
18	34.92	21.44	14.27	42.88	32.16	88.9
20	38.1	21.44	14.27	46.02	35.33	101.6
22	41.28	21.44	14.27	49.23	38.51	101.6
24	44.45	22.22	15.29	52.37	41.68	101.6

NOTE :
 1) "H" DISTANCE WILL BE FROM CENTER-TO-CENTER OF LUG HOLE
 2) ROPE & CHAIN HAVE FREE ROTATION ON FASTENER
 3) ALL COMPONENTS ARE COMPLIANCE TO THE MS3181 SPECIFICATION REQUIREMENTS

REV	ECN NO.	DESCRIPTION	DATE	APR'VD
A		INITIAL RELEASE		

REVISIONS DETAILS

THIRD ANGLE PROJECTION	UNSPECIFIED TOLERANCE .X ± 0.38 .XX ± 0.25 ANGLE ± 1° UNIT-MILLIMETER
DRAWN	RHK
CHECKED	RPT
APR'VD	DSN
DATE	15-05-2024
SCALE - NTS	SHEET: 3OF1

INDUSTRIAL TOWN,
BANGALORE
INDIA - 560010
PH : +91 6363911299
sales@ampmil.com
www.ampmil.com

This document is the property of M/s. Ampmil Interconnect (P) Ltd., Rights of reproduction, utilization or disclosure to the third parties in any form whatsoever, is not allowed without the written consent of the Company.

DESCRIPTION	
MIL-DTL-26482 SI & SII PROTECTIVE COVER FOR RECEPTACLE	
PART NUMBER	AP3181-XXX
(FOR XXX CONFIGURATION REFER HOW TO ORDER DOCUMENT)	

REV
A