

PRODUCT DRAWING

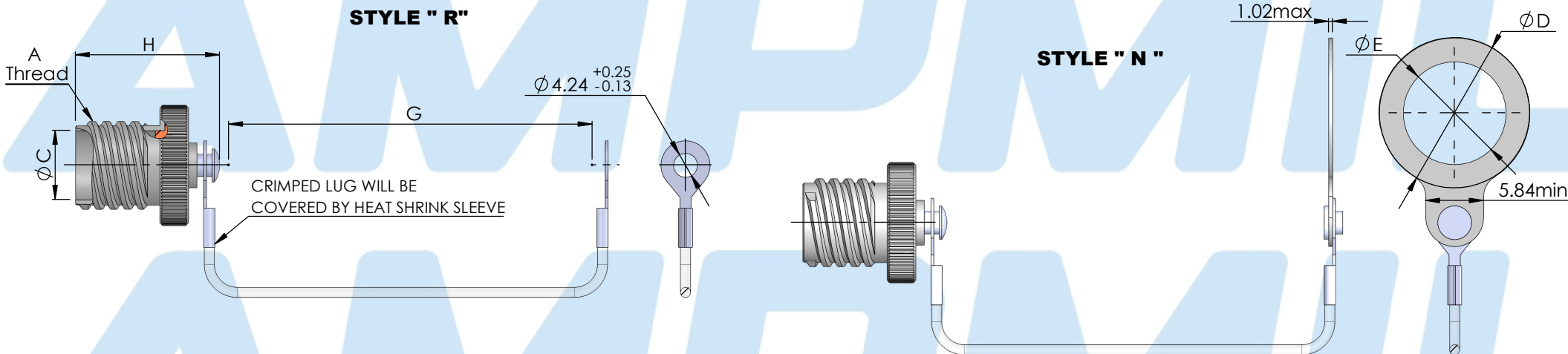

FOR ORDERING REFER AMPMIL "HOW TO ORDER DOCUMENT"

SPECIFICATION			
NO.	PART NAME	MATERIAL	REMARKS
01	SHELL	ALUMINIUM	AS PER ORDER
02	FASTENERS	STAINLESS STEEL	PASSIVATED
03	RING	STAINLESS STEEL	PASSIVATED
04	CHAIN	STAINLESS STEEL	PASSIVATED
05	GASKET	SILICON ELASTOMER	NATURAL
06	INSULATED ROPE	7STRAND STAINLESS STEEL	PASSIVATED
07	LUG	STAINLESS STEEL	PASSIVATED

SHELL SIZE	A	ØB	ØC	ØD	ØE	F	G	H
	THREAD-2B (in Inches)	max	+0.00 -0.15	max	min	± 2.0	+13.0 -7.0	max
9	0.6250-0.1P-0.3L-TS	23	12.5	24	13	20.1	127	30
11	0.7500-0.1P-0.3L-TS	26	15.75	27	18	20.1	127	30
13	0.8750-0.1P-0.3L-TS	31	19.53	30	20	20.1	127	30
15	1.0000-0.1P-0.3L-TS	33	22.71	31	23	20.1	127	30
17	1.1875-0.1P-0.3L-TS	37	25.88	37	26	20.1	127	30
19	1.2500-0.1P-0.3L-TS	40	28.55	40	29	20.1	127	30
21	1.3750-0.1P-0.3L-TS	44	31.72	44	32	20.1	127	30
23	1.5000-0.1P-0.3L-TS	46	34.9	46	34	20.1	127	30
25	1.6250-0.1P-0.3L-TS	50	38.07	49	39	20.1	127	30

NOTE :
 1) "G" DISTANCE WILL BE FROM CENTER-TO-CENTER OF LUG HOLE
 2) ROPE HAVE FREE ROTATION ON FASTENER
 3) ALL COMPONENTS ARE COMPLIANCE TO THE MIL-DTL-38999/32 SPECIFICATION REQUIREMENTS

REV	ECN NO.	DESCRIPTION	DATE	APR'VD
A		INITIAL RELEASE		

	UNSPECIFIED TOLERANCE .X ± 0.38 .XX ± 0.25 ANGLE ± 1° UNIT-MILLIMETER		INDUSTRIAL TOWN, BANGALORE, INDIA - 560010 PH : +91 6363911299 sales@ampmil.com www.ampmil.com
DRAWN: RHK CHECKED: RPT APR'VD: DSN	DATE: 15-05-2024 SCALE - NTS SHEET: 4 OF 1	MIL-DTL-38999/32 PROTECTIVE COVER FOR PLUG	DESCRIPTION PART NUMBER: AP38999/32-XXX (FOR XXX CONFIGURATION REFER HOW TO ORDER DOCUMENT)

This document is the property of M/s. Ampmil Interconnect (P) Ltd., Rights of reproduction, utilization or disclosure to the third parties in any form whatsoever, is not allowed without the written consent of the Company.

REV
A