

# PRODUCT DRAWING

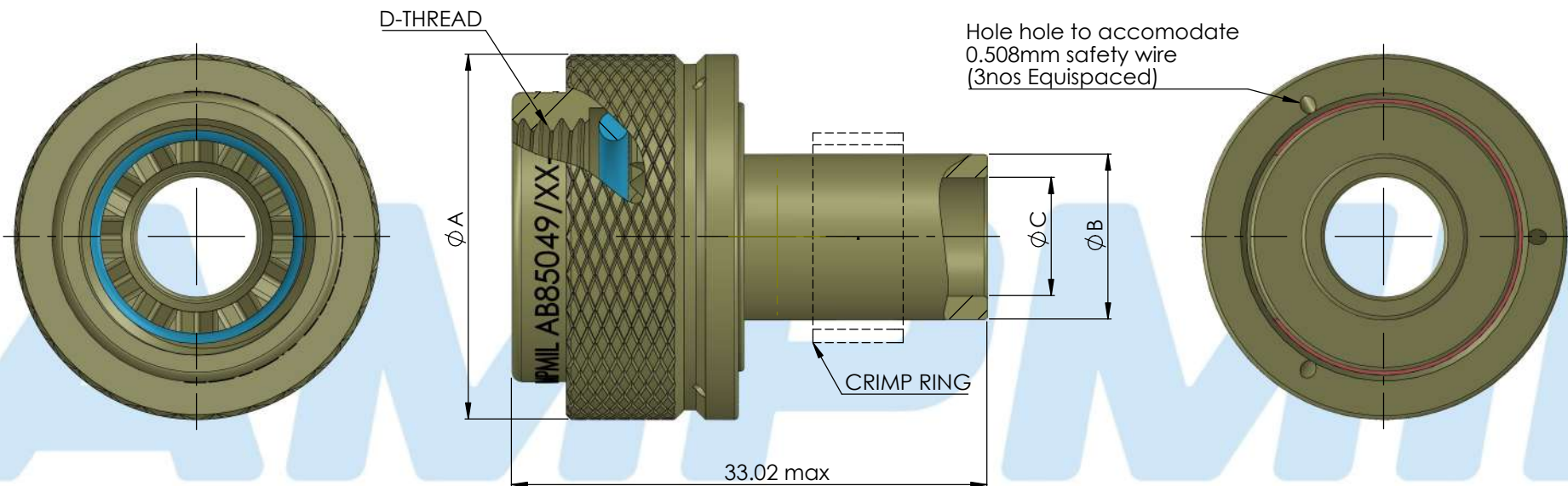

FOR ORDERING REFER AMPMIL "HOW TO ORDER DOCUMENT"

SHELL SIZE	SHELL SIZE CODE (REF)	ØA	ØB	ØC	ØD THREAD	AS85049/26-2 RING, SHIELD CRIMP (REF)
		MAX	MIN	± 0.381	CLASS 2B	
9	A	19.1	8.81	6.35	M12 X 1 -6H	-8
11	B	21.6	12.65	8.26	M15 X 1 -6H	-10
13	C	25.4	12.95	10.67	M18 X 1 -6H	-12
15	D	27.9	16	13.72	M22 X 1 -6H	-14
17	E	31.8	19.3	17.02	M25 X 1 -6H	-16
19	F	35.6	22.61	20.04	M28 X 1 -6H	-18
21	G	38.1	25.65	23.22	M31 X 1 -6H	-20
23	H	41.9	28.7	26.39	M34 X 1 -6H	-22
25	J	44.5	30.53	28.24	M37 X 1 -6H	-24

PARTS SPECIFICATION			
NO.	PART NAME	MATERIAL	REMARKS
01	SHELL	ALUMINIUM	
02	FASTENER	STAINLESS STEEL	PASSIVATED
03	ORING	SILICON ELASTOMER	

**NOTE:**

- 1) Coupling nut captivated to adapter body and free to rotate
- 2) Interface dimensions compliance to AS85049
- 3) Material and Finish in accordance with AS85049

REV	ECN NO.	DESCRIPTION	DATE	APPROVED
A		INITIAL REL.		
REVISIONS DETAILS				

	UNSPECIFIED TOLERANCE .X ± 0.38 .XX ± 0.25 ANGLE ± 1° UNIT-MILLIMETER	<p style="font-size: small;">RELIABLE CONNECTOR SOLUTIONS</p>	INDUSTRIAL TOWN, BANGALORE INDIA - 560010 PH : +91 6363911299 <a href="mailto:sales@ampmil.com">sales@ampmil.com</a> <a href="http://www.ampmil.com">www.ampmil.com</a>
DRAWN: RHK CHECKED: RPT APR'VD: DSN DATE: 15-05-2024 SCALE - NTS: SHEET: 1 OF 1	DESCRIPTION: CONNECTOR ACCESSORIES, ELECTRICAL, ADAPTER, SHRINKBOOT, CATEGORY 5 (MIL-DTL-38999 SERIES III AND IV CONNECTORS)		PART NUMBER: AB85049/20-XXX

This document is the property of M/s. Ampmil Interconnect (P) Ltd., Rights of reproduction, utilization or disclosure to the third parties in any form whatsoever, is not allowed without the written consent of the Company.

(FOR XXX CONFIGURATION REFER HOW TO ORDER DOCUMENT)