

# PRODUCT DRAWING

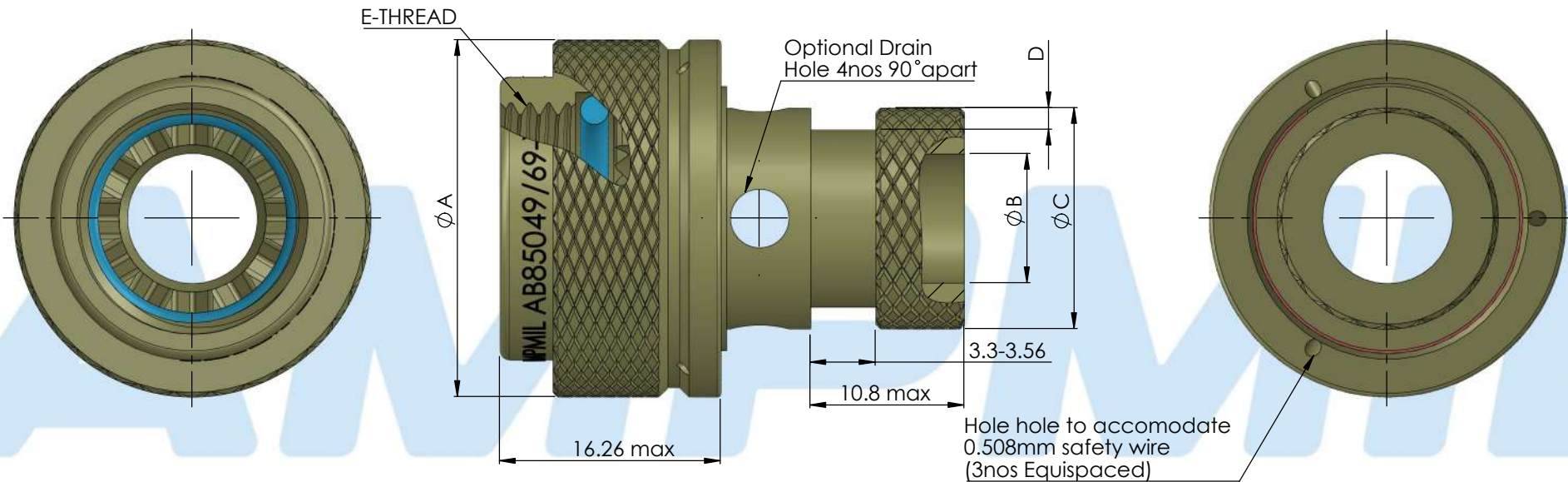

FOR ORDERING REFER AMPMIL  
"HOW TO ORDER DOCUMENT"



PARTS SPECIFICATION			
NO.	PART NAME	MATERIAL	REMARKS
01	SHELL	ALUMINIUM	
02	FASTENER	STAINLESS STEEL	PASSIVATED
03	ORING	SILICON ELASTOMER	

### NOTE:

- 1) Coupling nut captivated to adapter body and free to rotate
- 2) Interface dimensions compliance to AS85049
- 3) Material and Finish in accordance with AS85049

REV	ECN NO.	DESCRIPTION	DATE	APPROVED
A		INITIAL REL.		
REVISIONS DETAILS				

THIRD ANGLE PROJECTION	UNSPECIFIED TOLERANCE .X ± 0.38 .XX ± 0.25 ANGLE ± 1° UNIT-MILLIMETER	<p><b>AMP MIL</b> RELIABLE CONNECTOR SOLUTIONS</p>	INDUSTRIAL TOWN, BANGALORE INDIA - 560010 PH : +91 6363911299 sales@ampmil.com www.ampmil.com
DRAWN RHK	CHECKED RPT		DESCRIPTION CONNECTOR ACCESSORIES, ELECTRICAL, ADAPTER, SHRINKBOOT, CATEGORY 5 (MIL-DTL-38999 SERIES III AND IV CONNECTORS)
APR'VD DSN	DATE 15-05-2024	PART NUMBER AB85049/69-XXX	REV <b>A</b>
SCALE - NTS	SHEET: 1 OF 1	(FOR XXX CONFIGURATION REFER HOW TO ORDER DOCUMENT)	

This document is the property of M/s. Ampmil Interconnect (P) Ltd., Rights of reproduction, utilization or disclosure to the third parties in any form whatsoever, is not allowed without the written consent of the Company.

SHELL SIZE	SHELL SIZE CODE (REF)	ØA	ØB	ØC	ØD	E-THREAD
		MAX	MIN	MAX	+0.20 -0.00	
9	A	19.1	6.35	13.54	1.12	M12 X 1 -6H
11	B	21.6	9.52	15.37	1.12	M15 X 1 -6H
13	C	25.4	12.7	19.66	1.12	M18 X 1 -6H
15	D	29.2	15.88	21.29	1.12	M22 X 1 -6H
17	E	31.8	19.05	24.46	1.12	M25 X 1 -6H
19	F	35.6	20.62	26.47	1.12	M28 X 1 -6H
21	G	39.4	23.8	30.91	1.75	M31 X 1 -6H
23	H	41.9	26.97	34.42	1.75	M34 X 1 -6H
25	J	47	30.18	36.65	1.75	M37 X 1 -6H